

NO.	REVISION	BY	DATE

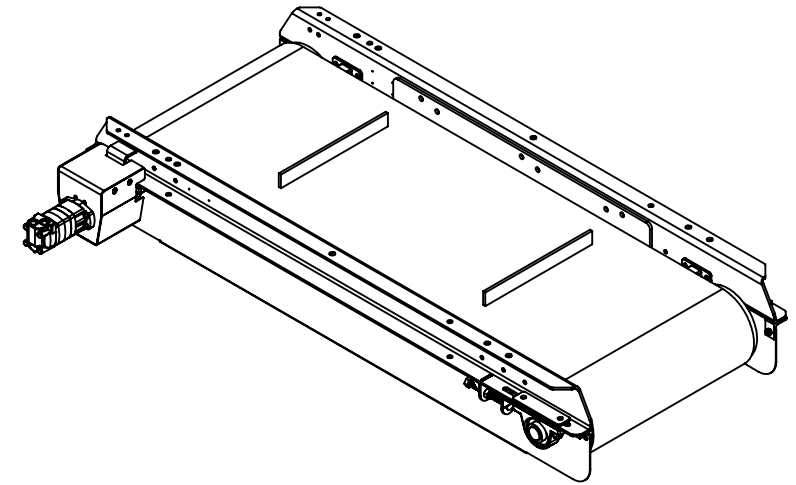
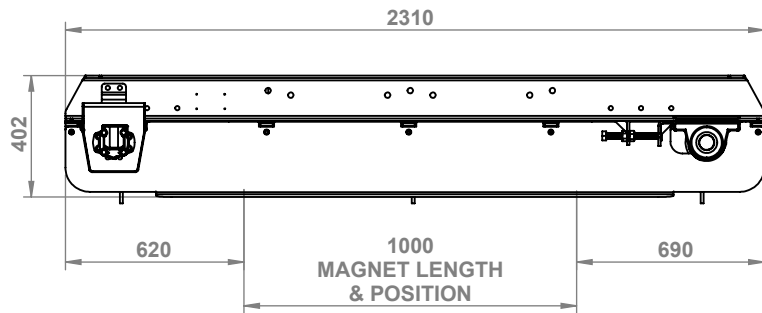
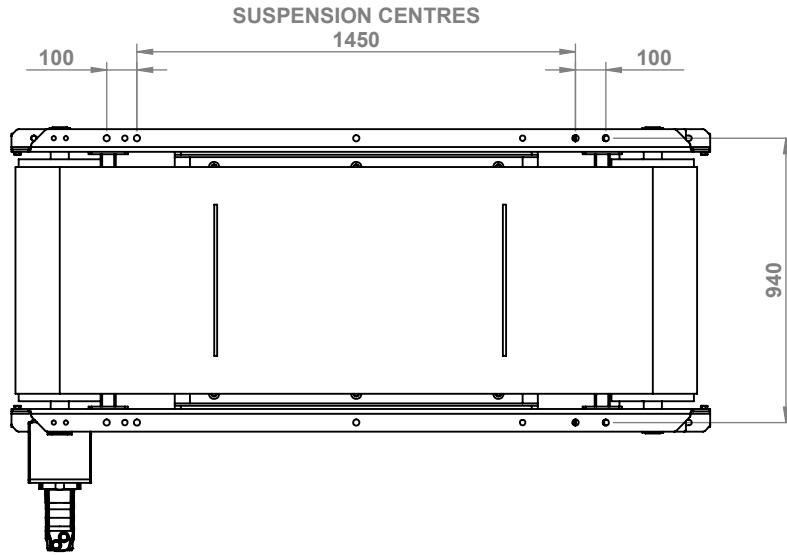

**400CC
HYDRAULIC MOTOR**

**FLOW RATE:
APPROX. 40LPM
(1.4M/S LINEAR
BELT SPEED)**

**PRESSURE DROP:
MAX 23 BAR.**

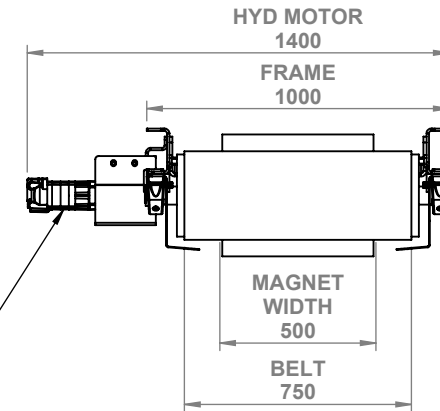

DO NOT SCALE DRAWING

ALL DIMENSIONS IN MM UNLESS OTHERWISE STATED

TOLERANCES EXCEPT AS NOTED

ANGLE ± 1°
HOLE +1, -0
MACHINE ± 0.001

DIMS 0-999 ± 1
DIMS 1000-2499 ± 2
DIMS 2500- ± 3

DRAWN BY:

E.McG

DEBUR AND BREAK SHARP EDGES

**ALL MAUFACTURING PARTS TO BE
PAINTED AND HAVE NO SHARP
EDGES**

ALL DRAWINGS ARE PROPERTY OF CONVEYORTEK
LTD AND SHOULD NOT BE REPRODUCED OR
DISTRIBUTED WITHOUT PERMISSION

COPYRIGHT © CONVEYORTEK LTD



Quantity:

MATERIAL:

DATE: 31/08/2016

WEIGHT: **APPROX. 1050 KG**

DWG NO.

CORE 1000 D SP HYD

SCALE:1:25

SHEET 1 OF 1

TITLE:

CORE 1000 D SP HYD

A4