

NO.	REVISION	BY	DATE

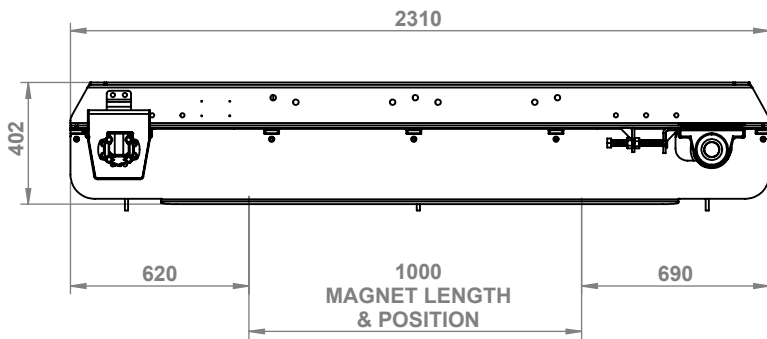
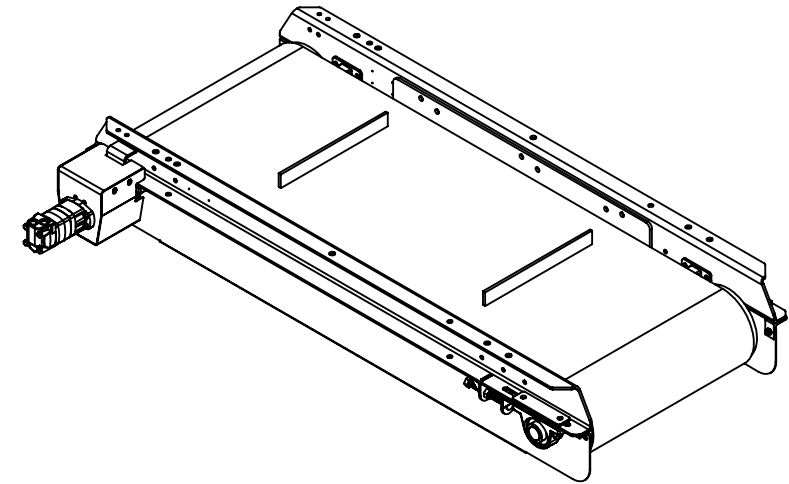
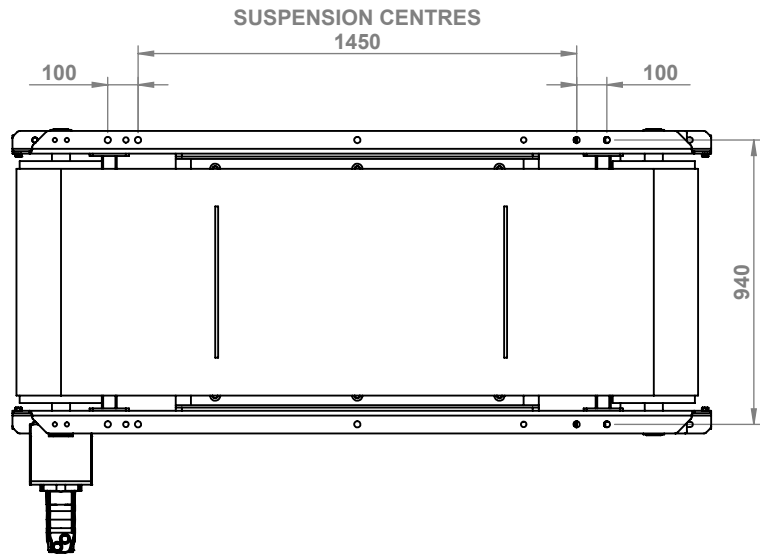

400CC  
HYDRAULIC MOTOR

FLOW RATE:  
APPROX. 40LPM  
(1.4M/S LINEAR  
BELT SPEED)

PRESSURE DROP:  
MAX 23 BAR.

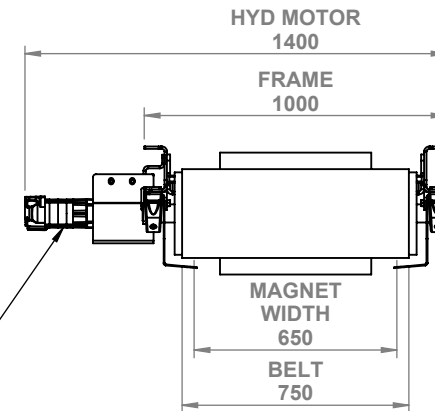

DO NOT SCALE DRAWING

ALL DIMENSIONS IN MM UNLESS OTHERWISE STATED

TOLERANCES EXCEPT AS NOTED

ANGLE ± 1°  
HOLE +1, -0  
MACHINE ± 0.001

DIMS 0-999 ± 1  
DIMS 1000-2499 ± 2  
DIMS 2500- ± 3

DRAWN BY:

E.McG

DEBUR AND BREAK SHARP EDGES

**ALL MAUFACTURING PARTS TO BE  
PAINTED AND HAVE NO SHARP  
EDGES**

ALL DRAWINGS ARE PROPERTY OF CONVEYORTEK  
LTD AND SHOULD NOT BE REPRODUCED OR  
DISTRIBUTED WITHOUT PERMISSION

COPYRIGHT © CONVEYORTEK LTD



Quantity:

**MATERIAL:**

TITLE:

**CORE 1000 D TP HYD**

DWG NO.

**CORE 1000 D TP HYD**

A4

DATE: 31/08/2016

WEIGHT: **APPROX. 1250 KG**

SCALE:1:25

SHEET 1 OF 1