

NO.	REVISION	BY	DATE

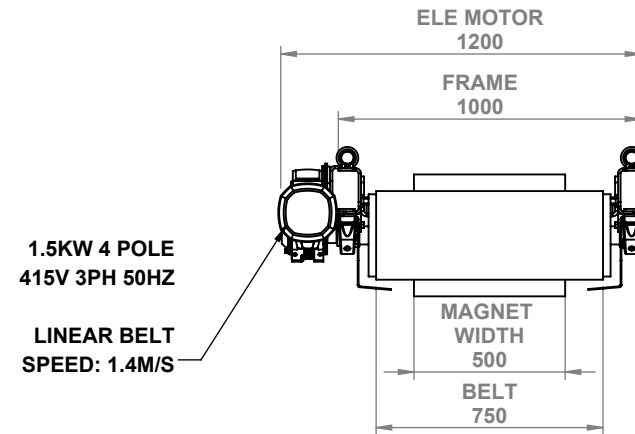
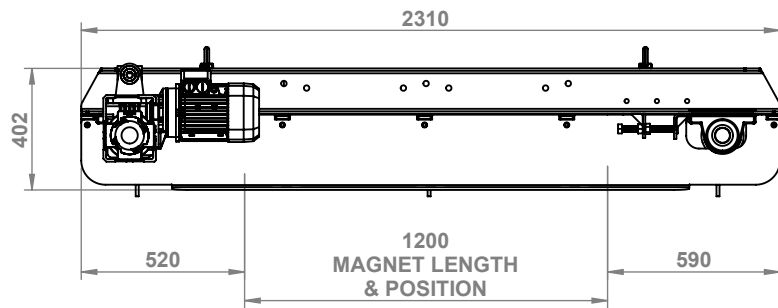
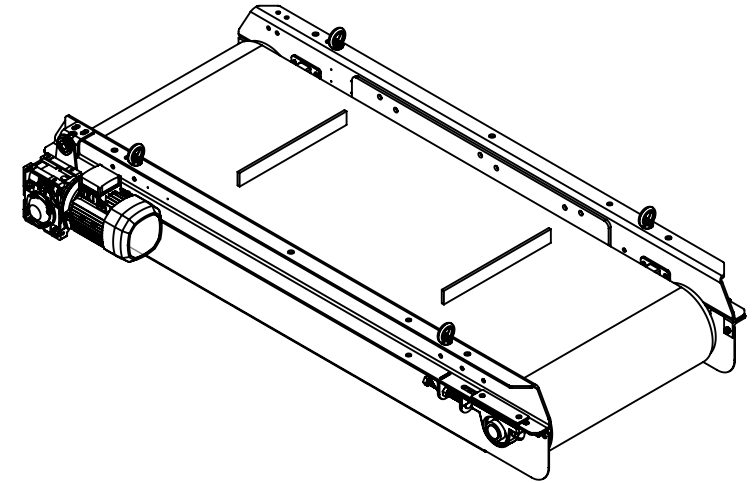
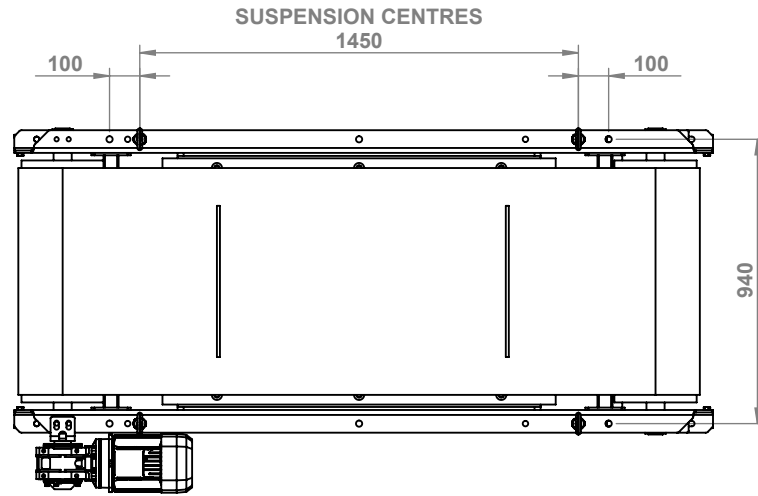

DO NOT SCALE DRAWING      ALL DIMENSIONS IN MM UNLESS OTHERWISE STATED

TOLERANCES EXCEPT AS NOTED	
ANGLE	± 1°
HOLE	+ 1, -0
MACHINE	± 0.001
DIMS 0-999	± 1
DIMS 1000-2499	± 2
DIMS 2500-	± 3

DRAWN BY: E.McG

DEBUR AND BREAK SHARP EDGES

**ALL MAUFACTURING PARTS TO BE PAINTED AND HAVE NO SHARP EDGES**

ALL DRAWINGS ARE PROPERTY OF CONVEYORTEK LTD AND SHOULD NOT BE REPRODUCED OR DISTRIBUTED WITHOUT PERMISSION

COPYRIGHT © CONVEYORTEK LTD

**conveyortek**

**Quantity:**

**MATERIAL:**

TITLE:

**CORE 1200 D SP ELE**

DWG NO.:

**CORE 1200 D SP ELE**

A4