

NO.	REVISION	BY	DATE

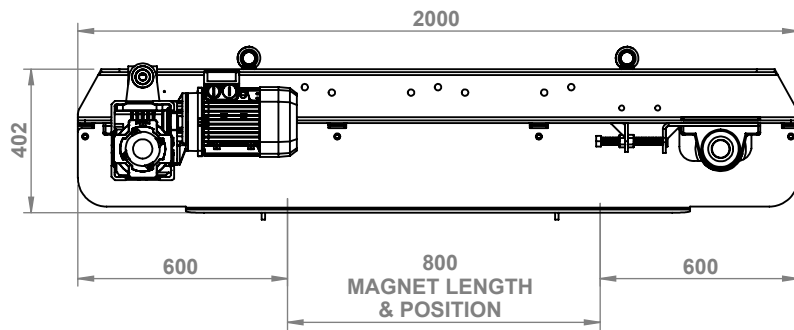

1.5KW 4 POLE  
415V 3PH 50HZ

LINEAR BELT  
SPEED: 1.4M/S

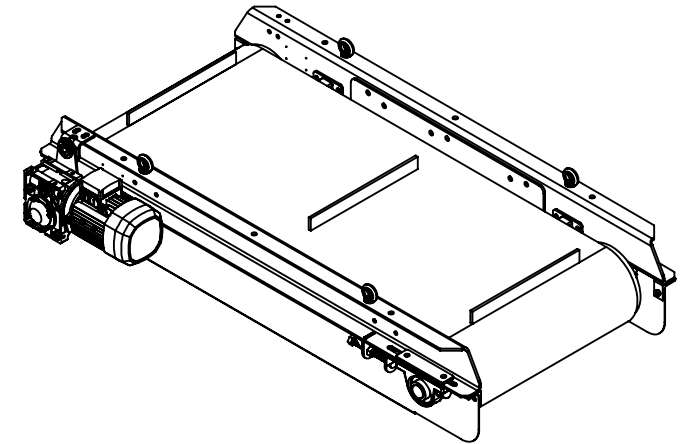
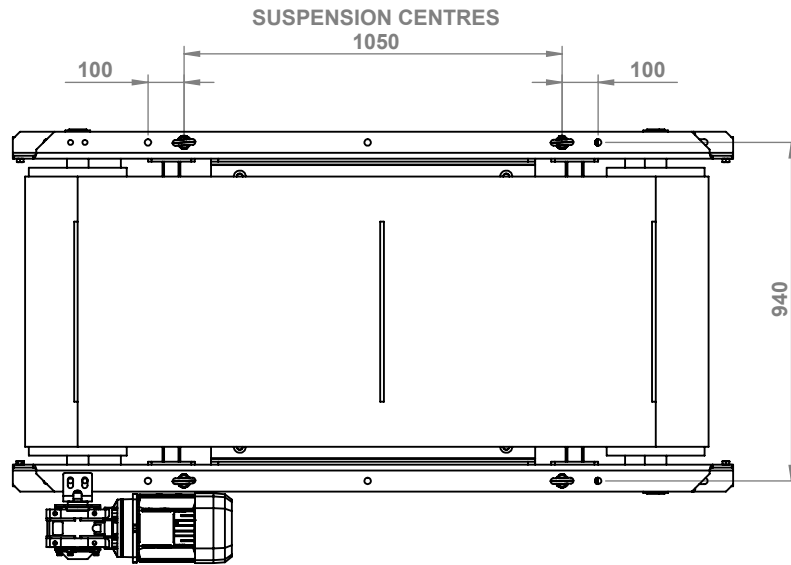
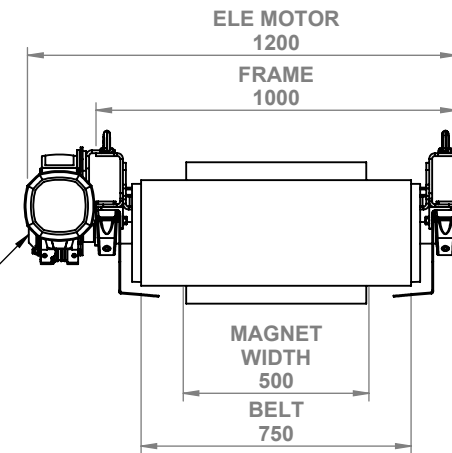

DO NOT SCALE DRAWING

ALL DIMENSIONS IN MM UNLESS OTHERWISE STATED

TOLERANCES EXCEPT AS NOTED

ANGLE ± 1°  
HOLE +1, -0  
MACHINE ± 0.001

DIMS 0-999 ± 1  
DIMS 1000-2499 ± 2  
DIMS 2500- ± 3

DRAWN BY:

E.McG

DEBUR AND BREAK SHARP EDGES

**ALL MAUFACTURING PARTS TO BE PAINTED AND HAVE NO SHARP EDGES**

ALL DRAWINGS ARE PROPERTY OF CONVEYORTEK LTD AND SHOULD NOT BE REPRODUCED OR DISTRIBUTED WITHOUT PERMISSION

COPYRIGHT © CONVEYORTEK LTD



Quantity:

**MATERIAL:**

DATE: 29/08/2016

WEIGHT: **APPROX. 900 KG**

DWG NO.

**CORE 800 D SP ELE**

SCALE:1:21

SHEET 1 OF 1

TITLE:

**CORE 800 D SP ELE**

A4