

NO.	REVISION	BY	DATE

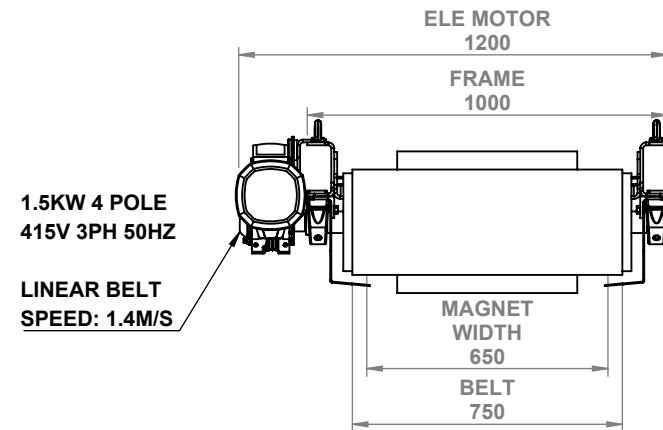
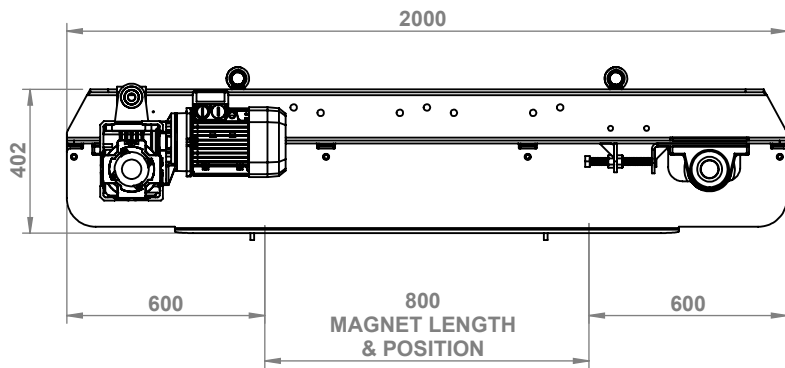
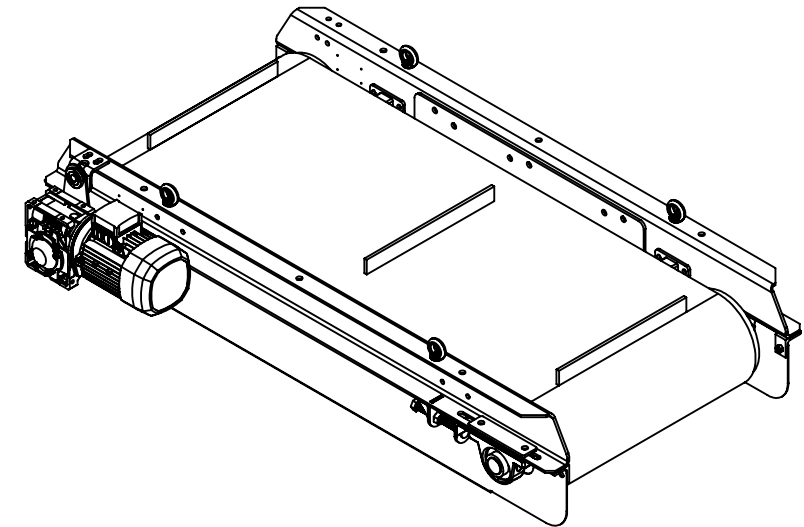
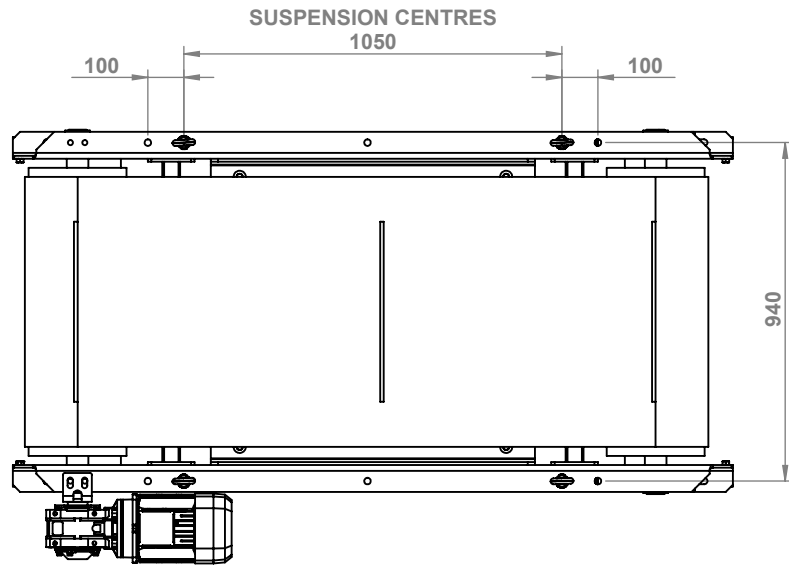

DO NOT SCALE DRAWING ALL DIMENSIONS IN MM UNLESS OTHERWISE STATED

TOLERANCES EXCEPT AS NOTED	
ANGLE	± 1°
HOLE	+ 1, -0
MACHINE	± 0.001
DIMS 0-999	± 1
DIMS 1000-2499	± 2
DIMS 2500-	± 3

DRAWN BY: E.McG

DEBUR AND BREAK SHARP EDGES

ALL MAUFACTURING PARTS TO BE PAINTED AND HAVE NO SHARP EDGES

ALL DRAWINGS ARE PROPERTY OF CONVEYORTEK LTD AND SHOULD NOT BE REPRODUCED OR DISTRIBUTED WITHOUT PERMISSION

COPYRIGHT © CONVEYORTEK LTD

Quantity: **MATERIAL:**

TITLE:	
CORE 800 D TP ELE	
DWG NO.	A4
CORE 800 D TP ELE	